

NEWALL



NEWALL

Linear Encoder



Company Profile

Newall, founded in Peterborough, England in 1968 and now a wholly owned subsidiary of BEI Technologies Inc., a Schneider Electric Company, has dedicated itself to providing the automation, machine tool and other machinery and production industries with leading edge technologies that increase productivity and machine tool efficiency.

In 1973, continuous design and development of Newall's technologies gave rise to the reliable and highly accurate Spherosyn™ and Microsyn™ Linear Encoders. The range now also includes incremental and absolute versions, available with industry standard output signals which can be interfaced with all major CNC, NC, PLC and PC products.

The latest SHG and MHG Linear Encoders incorporate a truly unique design in that none of the electrical or measuring components are exposed to harsh workshop environments and they will continue to provide accurate and reliable readings even when fully submerged in water, oil or coolant. For this reason all of the Newall linear encoder range carry an IP67 (NEMA 6) environmental rating.

Newall's products range also includes a wide range of Digital Readout systems; each specifically designed and dedicated to increasing machine productivity. The Digital Readout range has developed to become the most advanced readouts available today and combined with the Spherosyn™ and Microsyn™ technology encoders, is one of the reasons why the Newall range is a market leader.

Over 85% of its products are exported, with distribution and service outlets in over 63 countries. Newall actively supports these markets with a worldwide network of fully trained sales and service personnel. In addition offices are located in mainland Europe and the United States. Newall conforms to ISO 9001 and, in 1998, it was awarded the prestigious Queen's Award for Export Achievement.

Linear Encoder Overview

The recent advancements of Digital Signal Processors (DSPs) alongside high-speed analogue to digital conversion ICs has allowed the Spherosyn® technology to provide feedback for a wide range of signal protocols. This allows all Newall encoders to carry an IP67 (NEMA 6) environmental rating and will continue to provide accurate and reliable readings even when fully submerged in water, oil or coolant. No other linear encoder can equal the durability and reliability of the Newall encoders. Newall encoders can interface with all major CNC, NC, PLC and PC products.

- **IP67 rating (NEMA Type 6)**
- **Withstands dust, dirt, oil and other harsh environmental conditions**
- **No mechanical wear characteristics**
- **Requires no cleaning or maintenance**
- **High tolerance to shock and vibration**

Linear Encoder Overview

Incremental

Newall Incremental encoders provide quadrature square wave or sine-cosine feedback signals that allow for direct integration to servo driven applications.

Newall encoders are based upon Spherosyn technology and operate on the principle of electromagnetic induction. An electromagnetic field is generated by inducing a 10kHz sinusoidal current through a single drive coil within the reader head. This field interacts with the nickel chrome elements contained in the scale.

A set of four pickup coils detect variations in the induced field which are then combined and processed by the electronic circuitry to generate a signal that varies as the head moves along the scale. Depending on the position of the reader head as it passes over each element, the phase shift of this pickup signal relative to the drive signal will vary between 0 and 360 degrees. A high-speed digital-signal-processor (DSP) converts the analogue signal to an industry standard differential quadrature signal. The DSP also generates the periodic reference marker pulse.

Absolute

Newall Absolute encoders provide a true absolute position immediately upon power-up. The encoder does not use batteries or static memory to retain the positional data. True position can be re-acquired once power is applied, regardless of duration or power-off movements.

The scale is comprised of a stainless steel tube that houses a column of precision nickel-chrome elements. Coded inserts are placed between the elements in such a manner as not to interfere with the geometry of the system contact.

The aluminium cast reader head contains a coil assembly, the supporting electronics and a sensor array that detects the target that is embedded in the coded scale inserts. The cavity of the reader head is filled with an epoxy resin that fully seals the electronics and thus provides an IP67 rating.

A high-speed Digital-Signal-Processor (DSP) is utilized in order to process the positional data and to communicate the output protocols.

Distance-Coded

Newall's Distance-Coded Linear Encoder allows the controller to acquire an absolute position by moving the encoder systems across two uniquely spaced reference markers.

By using its internal absolute position count the encoder can mimic the Distance-Coded index marks that are generated by glass scales. An index pulse is generated at uniquely spaced intervals in the range of 4 to 10mm, varying by 20-micron increments. As the encoder is not constrained by any hardware limitations it can calculate and output almost any sequence of marker pulses.

TYPE	Incremental	Incremental	Incremental	Distance-Coded	Absolute
Product Group	SHG-T® & V®	MHG-T® & V®	MAG-TS	SHG-TC	SHG_A®
Protection	IP67	IP67	IP67	IP67	IP67
Accuracy Grade µm/m	±10	±5, 10	±25 + (20µm/m)	±3, 5, 10	±3, 5, 10
Maximum Traverse Speed	2MHz (2m/s at 1µm resolution)	2MHz (2m/s at 1µm resolution)	250KHz (4m/s at 10µm resolution)	8MHz (8m/s at 1µm resolution)	30m/s
Shock Vibration				100g (IEC 69-2-6) 30g (IEC 68-2-27)	

Encoder Selection Guide

	Application / Usage	Measuring Accuracy /m	Resolution Range	Measuring Length	Output Signal	Model-Code
FULL-SIZED ENCODERS	For long measuring lengths	$\pm 10\mu\text{m}$	0.5-10 μm	Single Scale 11m Modular to 30m	~11Vpp	SHG-VP
					~1Vpp with Single Point Reference	SHG-VS
					11 μA App	SHG-VM
					~1Vpp	SHG-VV
					TTL	SHG-TT
					TTL with Single Point Reference	SHG-TS
SUBLINE ENCODERS	For high accuracy with limited space	$\pm 5\mu\text{m}$	0.1-10 μm	Up to 1m	TTL	MHG-TT
	For long lengths with low accuracy requirements	$\pm 25\mu\text{m}$	10 μm	Up to 32m	~1Vpp	MHG-VP/VV/VM
FULL-SIZED ENCODERS	For absolute position measurement	$\pm 3, 5, 10\mu\text{m}$	0.5-10 μm	Up to 6.5m	TTL with Distance Coded Reference	SHG-TC
					RS485	SHG-A4
					SSI Gray or Binary	SHG-AG or AB
					RS232	SHG-A2
					Fanuc	SHG-AF
					Gray & Parity	SHG-AS

All Newall digital encoders can be connected to a wide range of PLC, CNC, NC and PC applications.

The choice of the encoder depends on five principal factors:

- The first is the level of precision required for the application i.e., in general, a saw conveyor requires a lower precision than a grinding machine.
- The second is the spatial limitations. For instance with an MHG Encoder you are able to fit into a much smaller area than an SHG Encoder.

• The third factor is the overall measuring length of the application.

• The fourth is the required resolution.

• The fifth is the output signal.

Measuring Methods

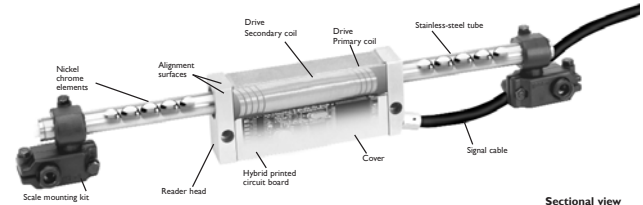

Sectional view

Spherosyn Technology

Incremental

Spherosyn technology is an inductive encoder that is made up of two main assemblies, the reader head and the scale. The scale is a length of stainless steel tube housing a column of precision elements. The elements are maintained under compression, the compression load being set during manufacturing to calibrate the scale. The head, which fits around the scale moves in a linear motion along the scale length, comprising a rectangular aluminium casting containing a coil assembly and electronics.

Figure 1 shows the arrangement of coils in the head. There are six sets of pick-up coils. Each set consists of four identical windings that are spaced at intervals of one pitch. As a result of this spacing each coil in a set is positioned over an identical part of an adjacent element. All the coils of a set are connected together in series. Over the pick-up coils is the drive coil. The element within the scale cause the permeability of the scale to vary periodically over a pitch. The voltages induced in each of the sets of pick-up coils vary according to the relative positions of the coils to the underlying

Figure 1

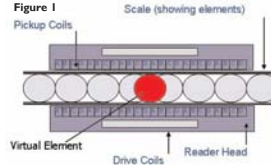

elements. The variation of the amplitude of the induced signals with displacement along the scale is shown in Figure 2a. The coils are spaced such that when one set of coils is at a maximum, e.g. set A, another set spaced one half an element pitch away, set C, will be at a minimum. These coil pairs are combined differentially to produce signals that vary with displacement as shown in Figure 2b.

These combined signals are phase shifted by the electronic circuits in the head. The A-C signal is advanced 45° and the D-B signal is retarded 45°. These signals are added together and filtered. The result is an output signal whose phase varies as the head is displaced along the scale.

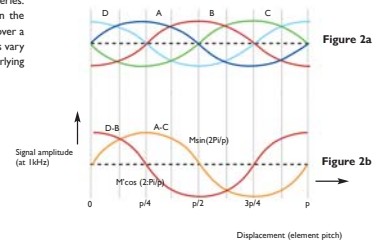

Figure 2a

Figure 2b

Measuring Methods

Spherosyn Technology - Incremental cont'd

The phase changes by 360° for each pitch of movement. This output signal is at the fundamental frequency of 10kHz and has a peak-to-peak amplitude of approximately 5V around a DC level of 5V. Thus the position measured is absolute over a single element, i.e. for every 12.7mm increment. Figure 3, shows a phase shift of 90° that equates directly to a position of 3.175mm relative to the zero phase position. Phase change of 90° relating to 1/4 of a pitch 3.175mm for Spherosyn technology. To achieve linear measurement, the total position is constructed by the addition of the absolute measurement value and the sum of the number of elements traversed since the encoder was referenced.

Encoders or position sensors can be broadly categorised into two families, DC operation or AC operation. In the former class lie optical and magnetic encoders both rotary and linear. Devices that use AC excitation are either inductive or capacitive. Examples of rotary inductive devices are resolvers and synchros whilst linear devices include LVDTs, Inductosyn and Newall encoders.

In AC systems, the signals containing the positional data are modulated AC signals at the fundamental operating frequency of the device. In DC systems, the signals are modulated DC, i.e. slowly varying DC levels.

DC signals are particularly subject to offset errors, drift and low frequency noise.

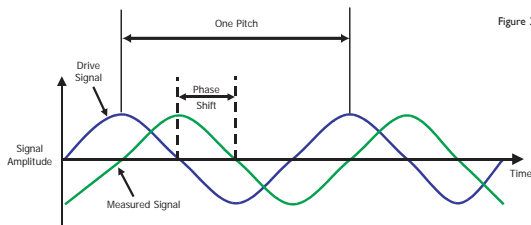

Figure 3

Offset errors can be countered by the use of techniques such as chopper stabilisation which, effectively, converts the signal to AC to eliminate the offset and then converts back. In AC systems the nulling of offset errors is inherent in the AC coupling used and no complex techniques need be applied.

Drift is a problem in DC systems, particularly optical where the lamps, LEDs or solar cells are subject to long-term ageing. Inductive systems are inherently stable being based on fixed physical properties such as turns ratios and permeability of the encoder parts. These do not change with time.

Low frequency noise, particularly mains power frequencies, can interfere with DC signals and cannot be blocked without severely degrading the system's response time. AC systems, working at a precise, fixed frequency, will employ low and high frequency filters without impacting upon response speed.

A criticism often aimed at inductive encoders is that their relatively long pitch length requires a much larger interpolation level for a given resolution than for an optical grating. This is true, but it is not mentioned that accurate interpolation is much more easily achieved, for the reasons given above, on AC systems than DC. The accuracies and resolutions that can be obtained from resolvers match those of their optical rotary counterparts. The same is true for Newall's linear encoders versus its linear optical or magnetic competitors.

Measuring Methods

Spherosyn Technology Absolute

The Newall Absolute SHG-A® Encoder is a breakthrough in linear measurement technology. Uniquely coded inserts are placed between the precision nickel chrome elements in the scale. The inserts are locked in position as part of the manufacturing process and contain a small magnetic target that can be detected by a series of hall sensors contained within the readerhead. The density of the inserts and the detectors within the readerhead allows the system to determine fully absolute position at any point in time.

Once the encoder has internally determined the true absolute position it is then a matter for the DSP processing to handle communications of the positional data to the outside world through the use of communications protocols such as SSI (Synchronous Serial Interface), Fanuc, RS232, RS485 etc. Furthermore, the internal positional information can be used to accurately emulate other forms of Pseudo-Absolute interfaces such



as Distance-Coded. Being a DSP based absolute system capable of a high level of processing, the encoders are error mapped during manufacturing against a laser interferometer. This error map is stored in FLASH memory allowing it to be applied in real-time thus resulting in a highly accurate system.

Distance-Coded references (Pseudo Absolute)

Distance-Coded reference markers allow the controller to acquire absolute position by moving the encoder system across 2 uniquely spaced reference marks. By using its internal absolute position count, a variant of the Absolute can mimic the Distance-Coded index marks that are generated by glass scales.

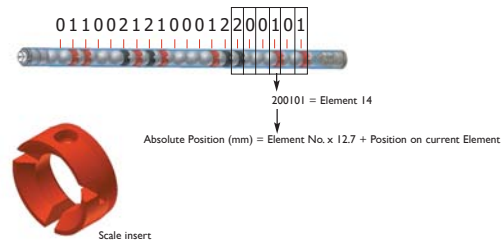

Measuring Methods

Magnasyn Technology Incremental

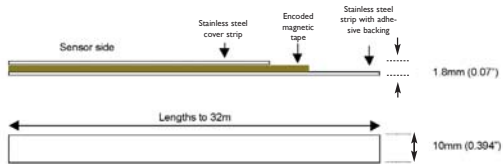

General

The Newall MAG encoder is comprised of a flexible tape scale which is mounted on a fixed surface of the machine, with or without an optional twin-track backing bar, and a reader head which is fastened to the moving part to be measured, arranged such that it travels in alignment with the scale.

The flexible nature of the tape scale makes the encoder ideal for rotary as well as linear applications.

For ease of installation, the adhesive side of the tape is attached directly to a machined surface. For applications where the mounting surface is uneven, the tape scale can be attached to an optional twin-track backing bar, supported by stand-offs.

A stainless steel cover strip is supplied to protect the encoded tape. The cover strip is attached to the encoded tape by way of its adhesive backing.

Principal of Operation

The tape scale is made up of a flexible magnetic rubber strip, sandwiched between a backing strip and a cover strip made from thin stainless steel. The encoded tape contains magnetic markers that are placed at 2mm intervals along the length of the tape.

As the incremental sensor in the reader head passes over the tape, the magnetic field is converted to an electrical signal, which is sampled by a micro controller. The field between the markers varies sinusoidally, which the micro controller can determine the position of the sensor in relation to each marker.

The analogue information is converted into an industry standard differential quadrature signal.

Reference Mark - RM

One index marker (short lengths of tape containing just one magnetic pole pair) can be fitted in the second track of the optional backing bar. This is detected by the index sensor in the reader head and output as the RM signal. More than one reference mark can be supplied on request.

Encoder Outputs

Signal Type Ordering Code	Signal Type	Description	Available on:
TT	Incremental TTL	TTL RS422 differential quadrature output	SHG, MHG,
TC	Incremental TTL-DC	TTL Distance Coded	SHG
TS	Incremental TTL-SP	TTL Single Point	SHG, MAG
VM	Incremental 1 μ App	1 μ Micro Amp	SHG, MHG
VPVV	Incremental -1Vpp	1 Volt Peak to Peak	SHG, MHG
VS	Incremental -1Vpp-SP	1 Volt Peak to Peak - Single Point	SHG
A2	Absolute - RS232	RS232	SHG
A4	Absolute - RS485	RS485	SHG
AB	Absolute - SSI-Binary	Synchronous Serial Interface - Binary Code	SHG
AF	Absolute - Fanuc	Fanuc Interface Protocol	SHG
AG	Absolute - SSI-Gray	Synchronous Serial Interface - Gray Code	SHG
AS	Absolute - Gray & Parity	Synchronous Serial Interface - Gray Code plus Even Parity Checksum	SHG

TT - TTL - Differential Quadrature

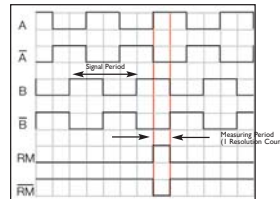

Encoder Connections

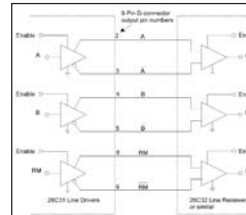

For encoder connections of distances greater than 22m refer to factory.

TT - TTL Output Signal - Differential Quadrature

Newall TT Series Linear Encoders provide a differential quadrature output at RS422 TTL levels. The output signals are transmitted via 9-core cable in accordance with the diagram below.

The periodic Reference Mark (RM) is synchronised with the A & B signals as shown in the diagram.

The distance between two successive edges of the combined pulse trains A and B is one measuring step (resolution).

Pin	Core	Function	Colour
1	7/0.15mm	N/C* (or OV)	Orange
2	7/0.15mm	Channel A	Green
3	Twisted Pair	Channel A	Yellow
4	7/0.15mm	Channel B	Blue
5	Twisted Pair	Channel B	Red
6	7/0.25mm	0V	White
7	7/0.25mm	5V	Black
8	7/0.15mm	Channel RM	Violet
9	Twisted Pair	Channel RM	Grey
GND	Screen	GND	---

* N/C = not connected

Encoder Outputs

TS & VS - Single Point

The SHG - TS & VS linear scales have a series of up to eight selectable reference markers spaced every 25.4mm, starting 78.5mm from the end of the scale. The reference point selected is dependent on the rotational alignment of the scale relative to the reader-head on installation. An installation LED, Bicolour green and red, is mounted on the reader head encoder face. Available with TTL output (TS) or ~1Vpp output (VS) when used with SCC-200 converter.

The MAG version contains a single point reference mark that can be applied at any point along the measuring length. Additional reference marks are available.

TC - Distance-Coded

The SHG - TC linear scales provide a unique output reference marker every 10 mm of movement along the length of the scale. This allows the absolute position value to be captured by the controller having moved over a maximum distance of 20 mm. This removes the requirement to traverse the full length of the scale to pick up the single point index and establish the alignment position.

VM - 1 1/2 App Sinusoidal

When used with SCC - 100 (see page 22)

VV - ~1Vpp Sinusoidal

When used with SCC - 100 (see page 22)

VP - ~1Vpp Sinusoidal

When used with SCC - 200 (see page 23)

A2 - RS232

Serial communication typically used to interface with PC control systems 'COM' port. This Electronics Industry Association (EIA) standard allows for data transmission from one transmitter to one receiver at data rates up to 20K bits/second and distances up to approximately 15m at the maximum data rate. A USB to Serial converter (Newall pt no 307-82340) is available to allow serial interface via a USB port.

A4 - RS485

The RS485 standard is a multi-point communication network, which specifies up to 32 drivers and 32 receivers on a single 2-wire Bus. A key feature is the ability to address individual devices. Newall's Linear Encoders are capable of being given and remembering a unique address tag which means multiple devices can be hung off the RS485 Bus.

Typical RS485 application multi point network

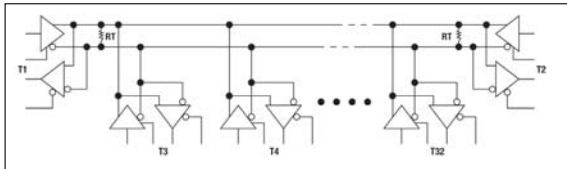

Encoder Outputs

FANUC OUTPUT FORMAT

AF - Absolute Fanuc

This protocol is proprietary to Fanuc and available on all of their control systems. The controller makes a request for positional data and the encoder has to respond correctly with data within a strictly controlled time state.

SSI OUTPUT FORMAT

The SSI (Synchronous Serial Interface) is a patented absolute interface by Max Stegmann GmbH. Newall absolute encoders offer this interface implementing the 24bit Gray code or Binary positional encoding. An even parity checksum is available on the AS version. The Most Significant Bit (MSB) is transmitted first (D0).

AB - Absolute SSI-Binary, 24 bit

AG - Absolute SSI-Gray, 24 bit

AS - Absolute SSI-Gray, 24 bit with Even Parity

(Parity is transmitted last as (D24) and is Even parity)

Cable Length (m)	Baud Rate (KHz)
< 50	≥ 400
< 100	≥ 300
< 200	≥ 200
< 400	≥ 100

Synchronous Serial Interface (SSI) is a serial protocol that provides absolute positional feedback for encoder applications. The SSI is a synchronous standard, meaning that the clock signals for the data exchange are provided by the controller and are typically limited to 1.5MHz. Transfer rates (baud) also dependent on cable lengths. The following table is recommended:

Binary is the position in decimal converted to its Binary equivalent and then expanded with additional zero's to fill the required data packet.

Example: 123456 (Decimal) =
11110001001000000 (Binary)

If this is shown in a 24-bit data packet =
000000011110001001000000

Gray is a binary code that only varies by one bit per transition.

Example:
0000
0001
0011
0010
0110 etc.

So the position in decimal is converted to pure binary and then converted to its Gray-code equivalent. This has the advantage over binary in that the maximum reading error is a single step.

Encoder Outputs

Signal Connection Table

Connector D Type 15 pin	-A2 RS232	-A4 RS485	-AB & AG SSI-Gray SSI Binary	-AS Gray and Parity	-AV SSI & ~1Vpp
1			SSI CLK	SSI CLK	Please refer to table on Page 23 for Connection Details via SCC200
2	PC	PC			
3	RS232 TX	RS232 TX			
4	RM	RM	RM	RM	
5	\bar{B}	\bar{B}	\bar{B}	\bar{B}	
6	\bar{A}	\bar{A}	\bar{A}	\bar{A}	
7	RS232 RX	RS232 RX			
8	+5VDC	+5VDC	+5VDC	+5VDC	
9			SSI CLK	SSI CLK	
10		RS485	SSI DATA	SSI DATA	
11		RS485	SSI DATA	SSI DATA	
12	RM	RM	RM	RM	
13	B	B	B	B	
14	A	A	A	A	
15	OV		OV	OV	

Blank connections are not implemented and are to be left unconnected.

Signal Connection Table for Fanuc Serial Absolute

Connector PCR-E20FS HONDA	-AF Fanuc
5	Fanuc RQ
9, 18, 20	+5VDC
6	Fanuc \bar{RQ}
1	Fanuc Data
2	Fanuc Data
12, 14, 16	OV



Absolute SHG-TC & SHG-A* Product Group

	SHG-TC	SHG-AF, AG, AB, AS, AV, A2, A4
Type	Inductive	Inductive
Output signal	TTL RS422 Differential quadrature	AF = Fanuc, AG = SSI Gray, AB = SSI Binary, AS = SSI Gray & Parity, AV = SSI and -1Vpp, A2 = RS232, A4 = RS485
Accuracy grade (µm/m)	+/- 5 (+/- 0.0002 in)	+/- 5 (+/- 0.0002 in)
Resolutions (µm)	1 (0.00005 in)	1 (0.00005 in)
Reference type	Distance-coded	None
Reference location	Max 20mm movement (0.8 in)	10mm movement except -AF & -AV No RM
Period of output (SCC-200 option)	20µm with converter	(-AV) 20µm with converter
Maximum traverse rate	8MHz (8m/s at 1µm resolution)	30m/s
Maximum Acc. / Dec.	100g / 980m/s ² (head moving)	100g / 980m/s ² (head moving)
Power supply	5VDC +/- 5% < 350mA	5VDC +/- 5% < 350mA
Processing latency	100µs	50µs
Shock (1 lms)	100g / 980m/s ² (IEC 69-2-6)	100g / 980m/s ² (IEC 69-2-6)
Vibration (55-2000Hz)	30g / 294m/s ² (IEC68-2-27)	30g / 294m/s ² (IEC68-2-27)
Ingress protection level	IP67 (NEMA 6)	IP67 (NEMA 6)
Operating temperature range	0 to 55°C (32 to 131°F)	0 to 55°C (32 to 131°F)
Storage temperature range	-20 to 70°C (-4 to 158°F)	-20 to 70°C (-4 to 158°F)
Magnetic field susceptibility	3mT (30 Gauss)	3mT (30 Gauss)
Radiated magnetic field	10mT (100 Gauss)	10mT (100 Gauss)
Overall cross-section	53.5 x 28.5mm (2x1 in)	53.5 x 28.5mm (2x1 in)
Scale material	316 grade stainless steel	316 grade stainless steel
Co-efficient of expansion	12ppm/°C	12ppm/°C
Scale OD	15.25mm (0.6in)	15.25mm (0.6in)
Maximum scale travel	6500mm (260in)	6500mm (260in)
Maximum single end mount measuring length	350mm (14in)	350mm (14in)
Maximum length between supports	1000mm (39 in)*	1000mm (39 in)*
Scale over-travel requirements	254mm (10 in)	254mm (10 in)
Moving force	20N	20N
Cable	15 core screened cable with PUR (polyurethane) cover with no armour	15 core screened cable with PUR (polyurethane) cover with no armour
Cable length	0.5m (20 in)	0.5m (20 in)
Minimum bend radius with PUR	25mm (1in)	25mm (1in)
Maximum cable length	22m (866 in)	22m (866 in)
Connector	D type 15 pin	D type 15 pin
EMC compliance	BS EN 61000-6-2 & BS EN 61000-6-4	BS EN 61000-6-2 & BS EN 61000-6-4
Diagnostics LED	Yes	Yes
OPTIONS		
Accuracy grade (µm/m)	+/- 3, 10 (+/- 0.00012 in, 0.0004 in)	+/- 3, 10 (+/- 0.00012 in, 0.0004 in)
Resolutions (µm)	0.5, 5, 10	0.5, 5, 10
Resolutions (in)	(0.00002 in, 0.0002 in, 0.0005 in)	(0.00002 in, 0.0002 in, 0.0005 in)
Cable armour	Fully interlocked stainless steel armour	Fully interlocked stainless steel armour
Minimum bend radius with armour	50.8mm (2 in)	50.8mm (2 in)
Connector	IP67 (NEMA 6)	IP67 (NEMA 6)

Absolute SHG-TC & SHG-A* Product Group

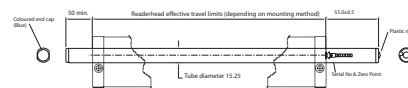
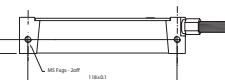
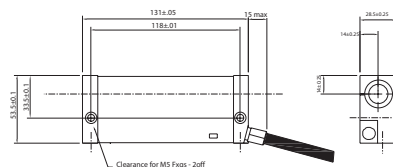

The encoder reader-head is to be installed within 50µm (0.002 in.) end-to-end relative to the axis of the scale in both horizontal and vertical planes

* Only applies for travels over 2540mm (100 in)

Incremental MHG-TT,VP,VV & VM Product Group

MHG-TT,VP,VV & VM	
Type	Inductive
Output signal	TTL RS422 Differential quadrature
Accuracy grade (µm/m)	+/-5 (+/- 0.0002 in)
Resolutions (µm)	1 (0.00005in)
Reference type	Periodic
Reference location	Every 5mm (0.2 in)
Period of output (SCC-100 option)	VV & VM 20 or 40µm with converter
Period of output (SCC-200 option)	VP 20µm with converter
Maximum traverse rate	2MHz (2m/s at 1µm resolution)
Maximum Acc. / Dec.	100g / 980m/s (head moving)
Power supply	5VDC +/- 5% < 70mA
Processing latency	100µs
Shock (11ms)	100g / 980m/s ² (IEC 69-2-6)
Vibration (55-2000Hz)	30g / 294m/s ² (IEC68-2-27)
Ingress protection level	IP67 (NEMA 6)
Operating temperature range	0 to 55°C (32 to 131°F)
Storage temperature range	-20 to 70°C (-4 to 158°F)
Magnetic field susceptibility	100mT (1000 Gauss)
Radiated magnetic field	Not measurable
Overall cross-section	35 x 25mm (1.5x1 in)
Scale material	Carbon fibre
Co-efficient of expansion	12ppm/°C
Scale OD	5.75mm (0.2 in)
Maximum scale travel	1000mm (39 in)
Maximum single end mount measuring length	350mm (14 in)
Scale over-travel requirements	178mm (7 in)
Moving force	10N
Cable	9 core screened cable with PUR (polyurethane) cover with no armour
Cable length	0.5m (20 in)
Minimum bend radius with PUR	25mm (1 in)
Maximum cable length	22m (866 in)
Connector	D type 9 pin, -VP D type 15 pin
EMC compliance	BS EN 50081-2 & BS EN 50082-2
OPTIONS	
Accuracy grade (µm/m)	+/- 10 (+/- 0.0004 in)
Resolutions (µm)	0.1, 0.2, 0.5, 2, 5 & 10
Resolutions (in)	(0.00005 in, 0.00001 in, 0.00002 in, 0.0001 in, 0.0002 in, 0.0005 in)
Cable armour	Fully interlocked stainless steel armour
Minimum bend radius with armour	50.8mm (2 in)
Connector	IP67 (NEMA 6)

Incremental MHG-TT,VP,VV & VM Product Group

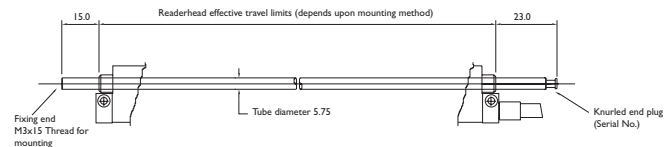
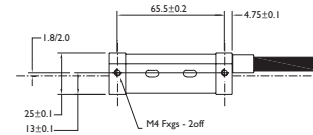
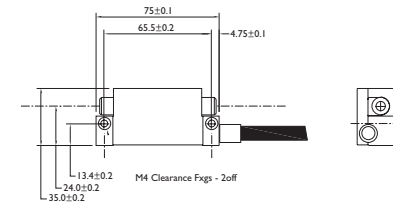

The encoder reader-head is to be installed within 50µm (0.002 in.) end-to-end relative to the axis of the scale in both horizontal and vertical planes

Incremental MAG-TT & MAG-TS Product Group

	MAG-TT, MAG-TS
Type	Magnetic tape
Output signal	TTL, RS422 Differential quadrature
Accuracy grade (µm/m)	+/- 25µm + (20µm/m) (+/- 0.001 in)
Resolutions (µm)	10 (0.0005 in)
Reference type	Single
Reference location	User select
Maximum traverse rate	4m/s
Maximum Acc. / Dec.	100g / 980m/s ² (head moving)
Power supply	5VDC +/- 5% < 200mA
Processing latency	Not applicable
Shock (11ms)	100g / 980m/s ² (IEC 69-2-6)
Vibration (55-2000Hz)	30g / 294m/s ² (IEC68-2-27)
Ingress protection level	IP67 (NEMA 6)
Operating temperature range	0 to 55°C (32 to 131°F)
Storage temperature range	-20 to 70°C (-4 to 158°F)
Magnetic field susceptibility	5mT (50 Gauss)
Radated magnetic field	9mT (90 Gauss) @ 0.6mm
Overall cross-section	24 x 26mm (1 x1 in)
Scale material	Rubber and steel
Co-efficient of expansion	1.6ppm/deg.K
Scale OD	10 x 1.8mm (0.4 x 0.07 in)
Maximum scale travel	32m (1260 in)
Maximum single end mount measuring length	Not applicable
Scale over-travel requirements	Not applicable
Moving force	Not applicable
Cable	9 core screened cable with PUR (polyurethane) cover with no armour
Cable length	0.5m (20 in)
Minimum bend radius with PUR	25mm (1 in)
Maximum cable length	22m (866 in)
Connector	D type 9 pin
EMC compliance	BS EN 50081-2 & BS EN 50082-2
OPTIONS	
Cable armour	Fully interlocked stainless steel armour
Minimum bend radius with armour	50.8mm (2 in)
Connector	IP67 (NEMA 6)

Incremental MAG-TT & MAG-TS Product Group

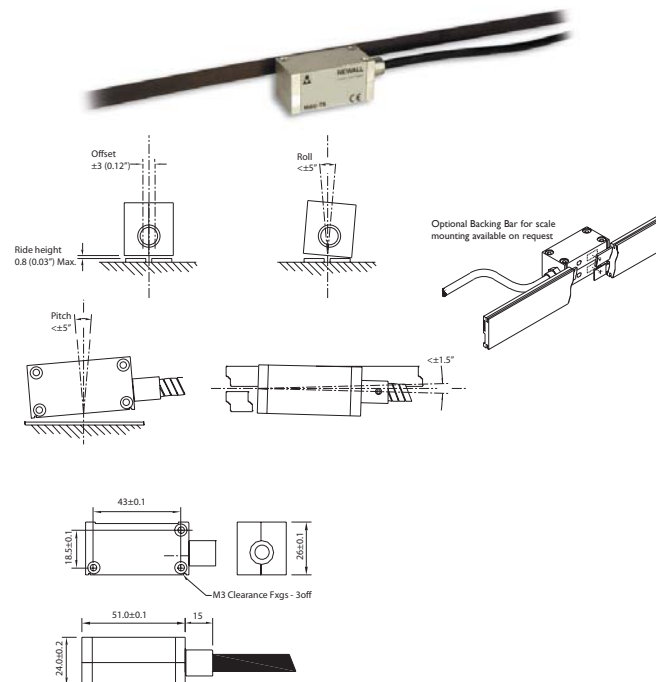

Connectors & Cable

9 Pin D Connector (IP54, NEMA 3)

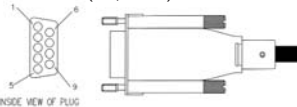

Colour	Pin	Function
Orange	1	N/C (or 0V)
Green	2	Channel A
Yellow	3	Channel A
Blue	4	Channel B
Red	5	Channel B
White	6	0V
Black	7	5V
Violet	8	Channel RM
Grey	9	Channel RM

15 Pin D Connector (IP54, NEMA 3)

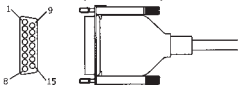

Pin	1	2	3	4
Colour	Light Green	Orange	Pink & White	Grey
Function	Fanuc RQ/SSI CLK	PC	RS232 TX	RM
Pin	5	6	7	8
Colour	Red	Yellow	Pink	Black
Function	B	X	RS232 RX	+5VDC
Pin	9	10	11	12
Colour	Light Green & White	Brown	Brown & White	Violet
Function	Fanuc RQ/SSI CLK	Fanuc Data / SSI Data / RS485	Fanuc Data / SSI Data / RS485	RM
Pin	13	14	15	Shell
Colour	Blue	Dark Green	White	Screen
Function	B	A	0V	GND

N/C - Not connected

12 Pin Connector (IP67, NEMA 6)



Pin	A	B	C	D
Colour	Orange	White	White	Yellow
Function	N/C (or 0V)	0V	0V	Channel A
Pin	E	F	G	H
Colour	Green	Red	Blue	Violet
Function	Channel A	Channel B	Channel B	Channel RM
Pin	J	K	L	M
Colour	Black	Black		Grey
Function	5V	5V		Channel RM

19 Pin Connector (IP67, NEMA 6)



Pin	A	B	C	D
Colour	Pink & White	Black	Black	Black
Function	RS232 TX	+5VDC	+5VDC	+5VDC
Pin	E	F	G	I
Colour	Grey	Violet	Orange	White
Function	RM	RM	PC	OV
Pin	K	L	M	N
Colour	White	Pink	Light Green & White	Brown
Function	OV	RS232 RX	Fanuc RQ / SSI CLK	Fanuc Data / SSI Data / RS485
Pin	O	P	S	T
Colour	Brown & White	Red	Yellow	Dark Green
Function	Fanuc Data / SSI Data / RS485	B	A	A
Pin	U	Shell		
Colour	Light Green	Screen		
Function	Fanuc RQ / SSI CLK			

Connectors & Cable

Extension Cables

There is a selection of extension cables available for the range of encoders. Therefore a cable selection guide has been devised to ensure you can purchase exactly which product you need.

Please specify one option per section as required

Section		Option	Option Description
Extension cable digital	ELD	Prefix applicable for all digital extension cables	
Connector readerhead end		09D0	9 pin D (IP54, NEMA 3)
		15D0	15 pin D (IP54, NEMA 3)
		09B0	12 pin round (IP67, NEMA 6)
		15B0	19 pin round (IP67, NEMA 6)
Cable length		035	3.5m cable
		050	5m cable
		070	7m cable
		100	10m cable
Termination output end		0D	9 pin D (IP54, NEMA 3)
		1D	15 pin D (IP54, NEMA 3)
		FL	Flying Leads (Tails)
		FA	Fanuc (Honda)
		AM	Amp
Armour		0	Armoured
		1	Non-Armoured

Extension cable for SCC200 to CNC, NC, PLC and PC connection

Section		Option	Option Description
Extension cable digital	ELD	Prefix applicable for all digital extension cables	
Connector SCC200 output	ISDS	15 pin D (IP54, NEMA 3)	
Cable length		005	0.5m cable
		010	1m cable
		015	1.5m cable
		035	3.5m cable
Termination output end		2D	15 pin D (IP54, NEMA 3), Siemens
		FL	Flying Leads (Tails)
Armour		0	Armoured
		1	Non Armoured

Universal Mounting Kits

Standard mounting kits are available for the range of encoders.

SHG Readerhead Mounting Kit - Part No 600-81890

SHG Scale Mounting Kit - Part No: 600-80120
US Part No: 600-80110
Thread size 5/16" -18 UNC

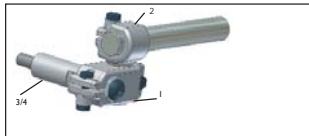

MHG Readerhead Mounting Kit - Part No 600-65620

MHG Scale Mounting Kit - Part No: MHBKITSTD
US Part No: MHBKITUSA
Thread size 1/4" -20 UNC

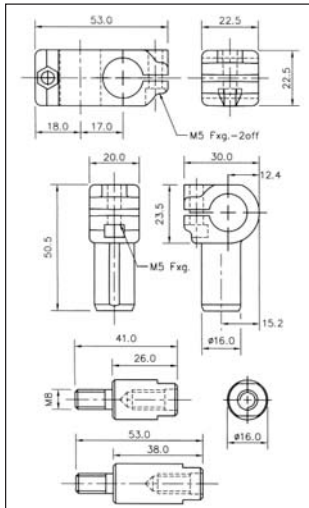
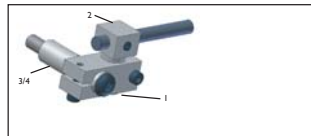

Item

1

2

3/4

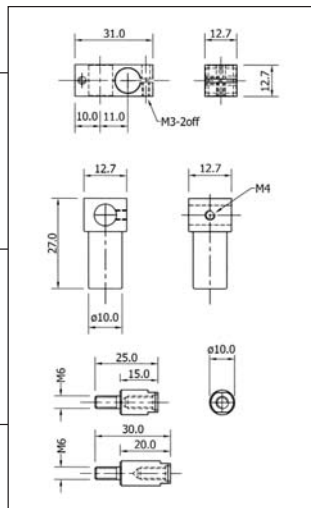

General Information

The Sphersyn Technology Advantage

Environmental Protection

All variants of Newall encoders carry an Ingress Protection (IP) rating of 67 (NEMA 6). The encoders are fully submersible and will continue to provide accurate and dependable readings under the harshest conditions. Unlike most glass based systems, no air purging is required. Dirt, swarf, cast iron dust, graphite dust and other common contaminants will not effect the performance of the system.

Shock and Vibration

In comparison to other linear displacement technologies, SHG and MHG are tolerant to high degrees of vibration and shock.

- Shock and Impact (11ms IEC 69-2-6):
Sphersyn technology = 1000m/s² (100g)
- Vibration (55 - 2000Hz IEC 68-2-27):
Sphersyn technology = 300m/s² (30g)

Slow Rate

Newall encoders will not skip count even at high traverse rates. In its TTL output form, a slow rate of up to 20 metres/second can be achieved, while the Absolute version carries a slow rate of up to 60 metres/second.

Reliability

Newall encoders require no regular cleaning or maintenance. Unlike non-contact systems, the encoders have no general wear characteristics. There are no LEDs to burn out or glasses to get scratched or broken. There are no roller bearings, leaf springs or other moving parts to wear out or fail.

Ease of Installation

Installation is simple and forgiving and can be accomplished in a fraction of the time as compared to other linear systems. Even with scale lengths up to 11 metres, machined surfaces or backing bars are not needed. For more compact installations, scales less than 508mm in length need only be supported on one end of the scale.

Accuracy, Repeatability and Resolution

The laser measurement system used to calibrate all of Newall scales have been calibrated by accredited laboratories providing traceability to UK national standards. The procedures comply with the requirements of British Standard Specification BS578/International Standard ISO10012-1. The National Physical Laboratory (NPL) calibrates the master standard certificate number 08A0149501. All Newall Calibration rigs are traceable back to this NPL standard. The calibration of the Newall scales and reader heads is conducted in a temperature controlled (21°C) environment.

Thermal Expansion

The thermal behaviour of the linear encoder is an essential criterion for the working accuracy of a machine tool. And thus it is common knowledge that the thermal behaviour of the encoder should match that of the workpiece.

Consequently, a 10° C temperature rise can result in a thermal expansion error for glass in the order of 40µm over 1m of travel. In practice, it is rare that thermal stability will be achieved within the machine, workpiece or encoder during normal operation due to rates of thermal behaviour and environmental conditions. As a result, errors due to thermal effects are impossible to quantify and may be greater or lower than those theoretically calculated. Such errors are minimised by ensuring that the encoder is as matched as possible to both the machine and workpiece.

Product Group	PPM	Steel/Iron (12ppm)	Differential
Glass	8	12	4
Aluminium	23	12	-11
Sphersyn*	12	12	0

*Sphersyn results measured by the Department of Physics University of Hull using strain gauge dilatometry with temperature compensation.

Newall reserves to change specifications to the products without notification and the company accept no liability for claims from any changes.

© 2005 - All proprietary rights, including design rights, copyrights and trademarks, in the content materials, information, data, images, graphics, typographical arrangements and photographs appearing in this brochure are and shall remain the property of Newall Measurement Systems Limited. No portion of this brochure or any of its content may be reproduced, duplicated, copied, distributed or otherwise utilised for any purpose without our express written consent.

NEWALL

Newall Measurement Systems Ltd, Technology Gateway, Cornwall Road, South Wigston, Leicester, LE18 4XH, UK
TEL +44 (0) 116 264 2730 • FAX +44 (0) 116 264 2731 • E-MAIL sales@newall.co.uk • WEB www.newall.co.uk

Newall Electronics Inc., 1778 Dividend Drive, Columbus, OH 43228, USA
TEL +1 614 771 0213 • FAX +1 614 771 0219 • E-MAIL sales@newall.com • WEB www.newall.com

