

## SPB-TT and SPB-TS Linear Encoder For Pressbrake applications



# SPB-TT and SPB-TS Linear Encoder For Pressbrake applications

# NEWALL

## Specification

	SPB-TS and SPB-TT
Accuracy	±10µm
Resolution	1µm or 5µm
Output Type	RS422 Differential Quadrature
Max.Traverse Speed	60m/min (198ft/min)
Max.Acceleration	100m/s <sup>2</sup> (10g)
Power Supply	5Vdc ±5% @ 85mA
Reference Mark	SPB-TS = User Selectable 1 from 8 SPB-TT = Periodic (12.7mm)
Moving Force	<5N
Sealing	IP67
Shock EN 60-068-2-27 (11ms)	980m/s <sup>2</sup> (100g)
Vibration EN60-068-2-6 (55... 2000Hz)	294m/s <sup>2</sup> (30g)
EMC	BS EN 50081-2 & BS EN 50082-2
Temperature (Storage)	-20° to +70°C
Temperature (Operation)	0° to +55°C
Measuring Length including Single End Mount	Travel + 306mm (12in)
Measuring Length without Single End Mount	Travel + 268mm (10.5")
Mounting Alignment Tolerance	±3mm (Press closed)

### Note:

For optimal performance the encoder should be installed with the scale vertically mounted with the reader-head at the bottom (mounting end) when the press is open.

## Encoder Assembly

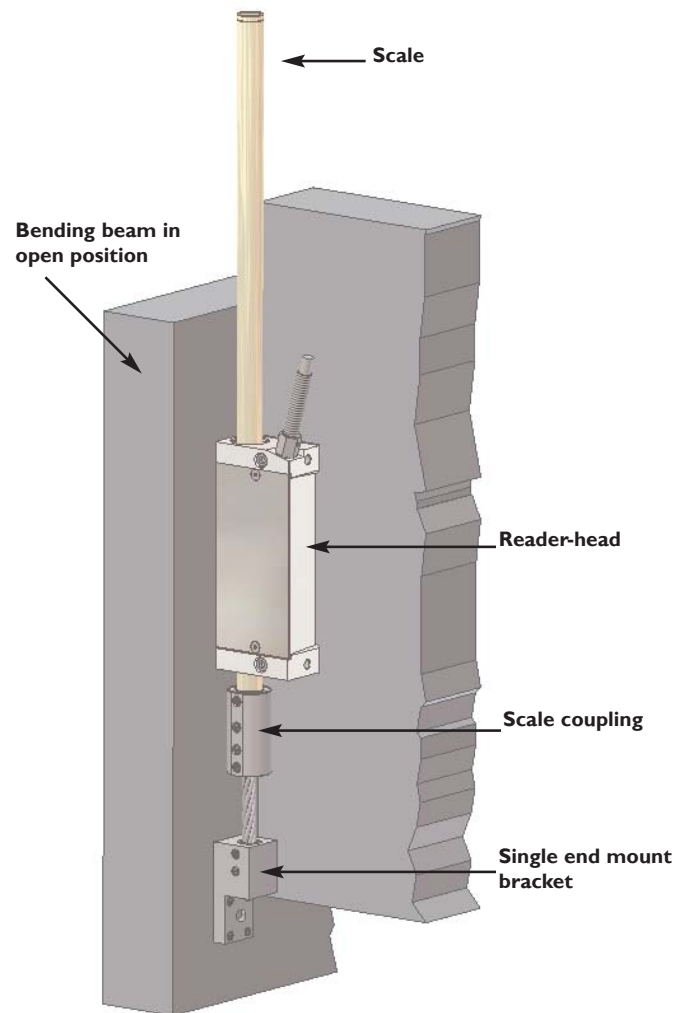

## Electrical



9D	Cable	Newall Colour	Function
1	7/0.15mm	Orange	N/C (or 0V)
2	7/0.15mm	Green	Channel A
3	Twisted Pair	Yellow	Channel /A
4	7/0.15mm	Blue	Channel B
5	Twisted Pair	Red	Channel /B
6	7/0.25mm	White	0V
7	7/0.15mm	Black	5V
8	7/0.25mm	Violet	Channel RM
9	Twisted Pair	Grey	Channel /RM
Shell	Overall Braid	---	Gnd

**!** Ensure cables are safely routed and connections are secure observing standard handling precautions. Incorrect connection or ESD discharge at the connections may result in permanent damage occurring.

# SPB-TT and SPB-TS Linear Encoder For Pressbrake applications

## Installation and Alignment

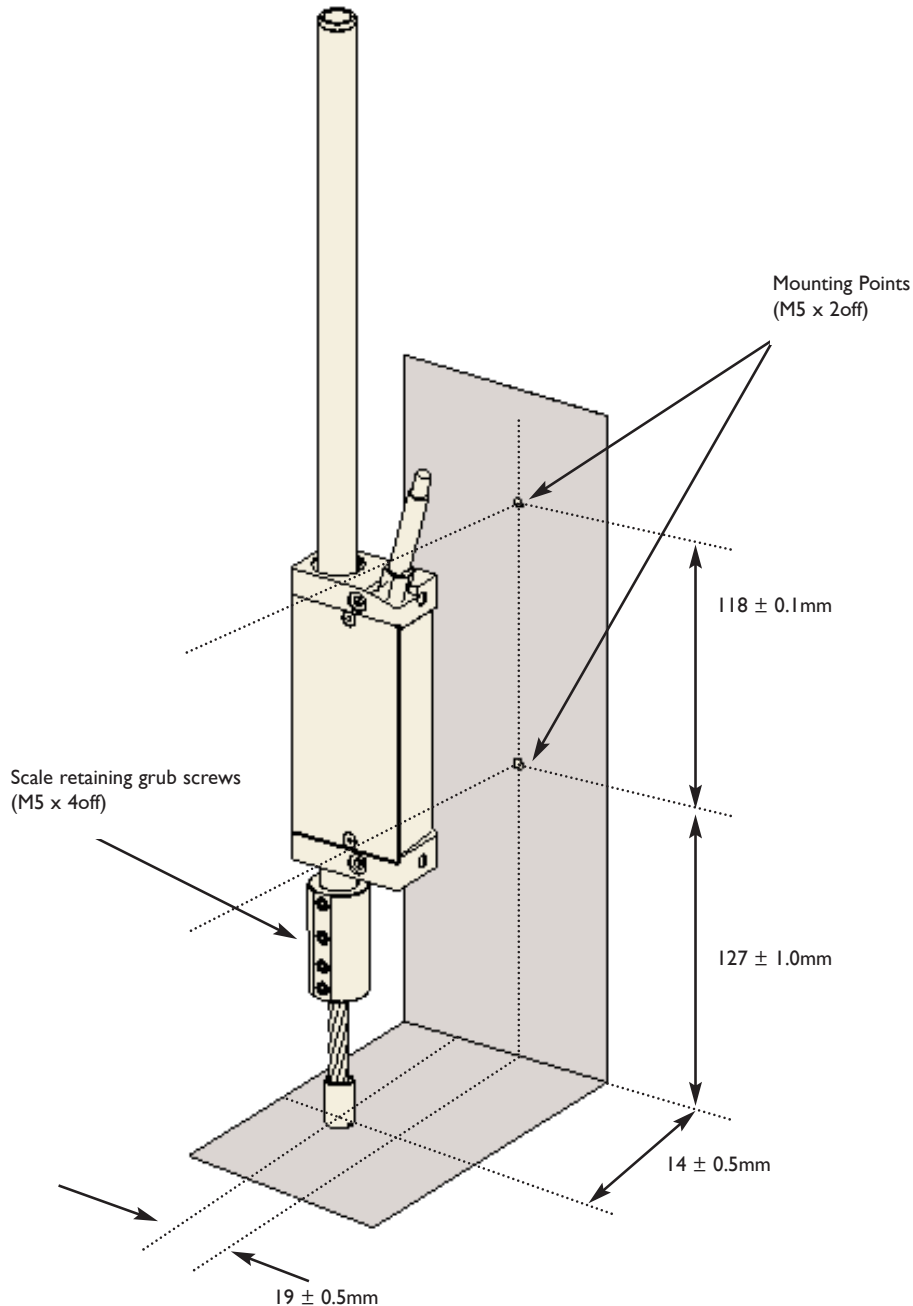

### Note:

For SPB-TS encoders ensure that the RED scale end marker is at the top most position. See the section on setting the single point reference mark before tightening the scale retaining grub screws.

# SPB-TT and SPB-TS Linear Encoder

## For Pressbrake applications

### Detailed Dimensions - Encoder

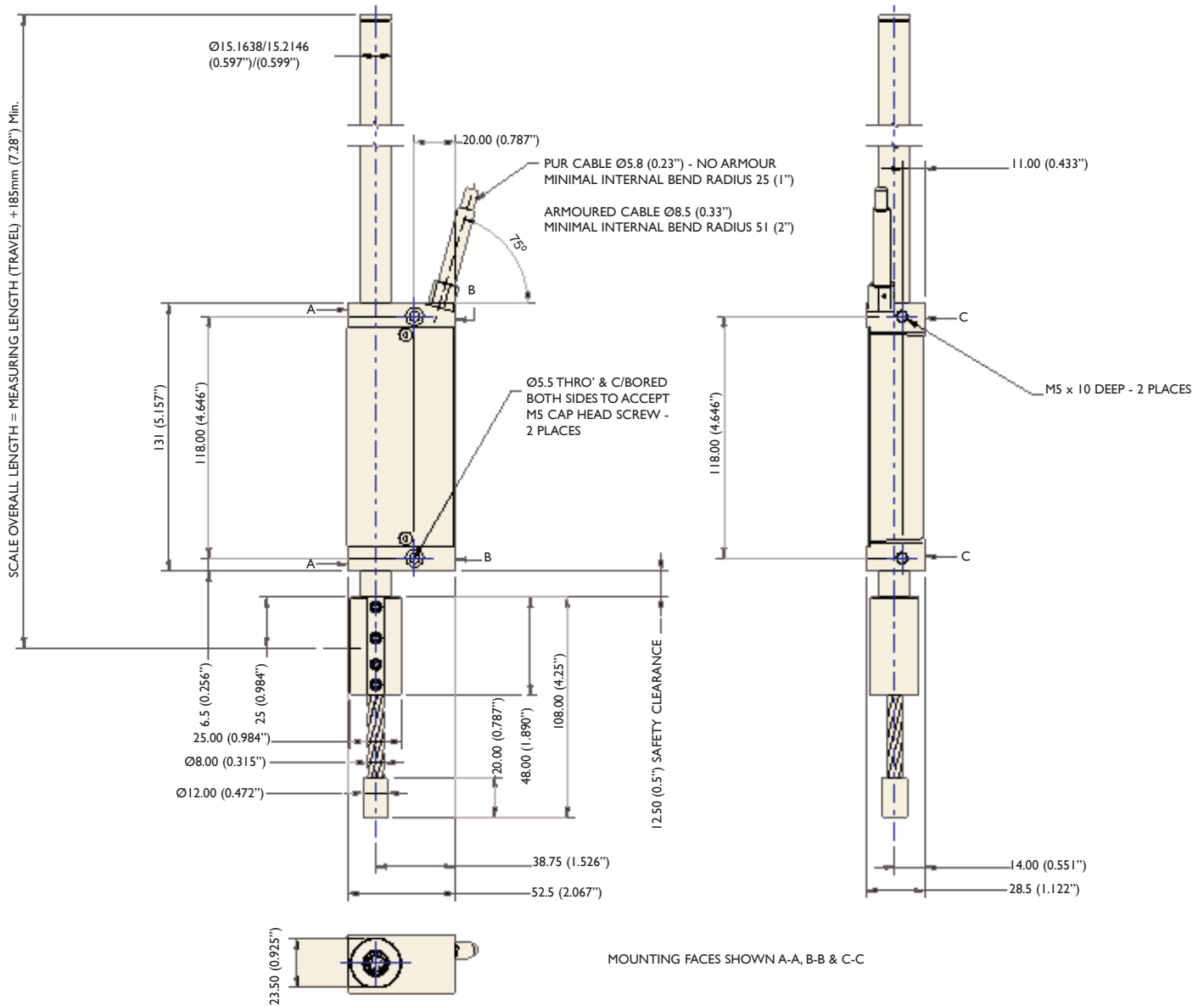



## SPB-TS with Single Point Reference For Pressbrake applications

The SPB-TS encoder incorporates a series of four internal reference marks options within the stainless steel scale. These are located along the length of the scale as per Figure 4, with each subsequent reference mark offset radially by 90°. This configuration allows the installer to select any one unique marker position by rotating the scale to present the desired reference mark to the sensor located within the reader-head. The number of reference marks within a scale is reduced where the measuring length is insufficient to include all options.

### Encoder Reference Mark Positions - Figure 4

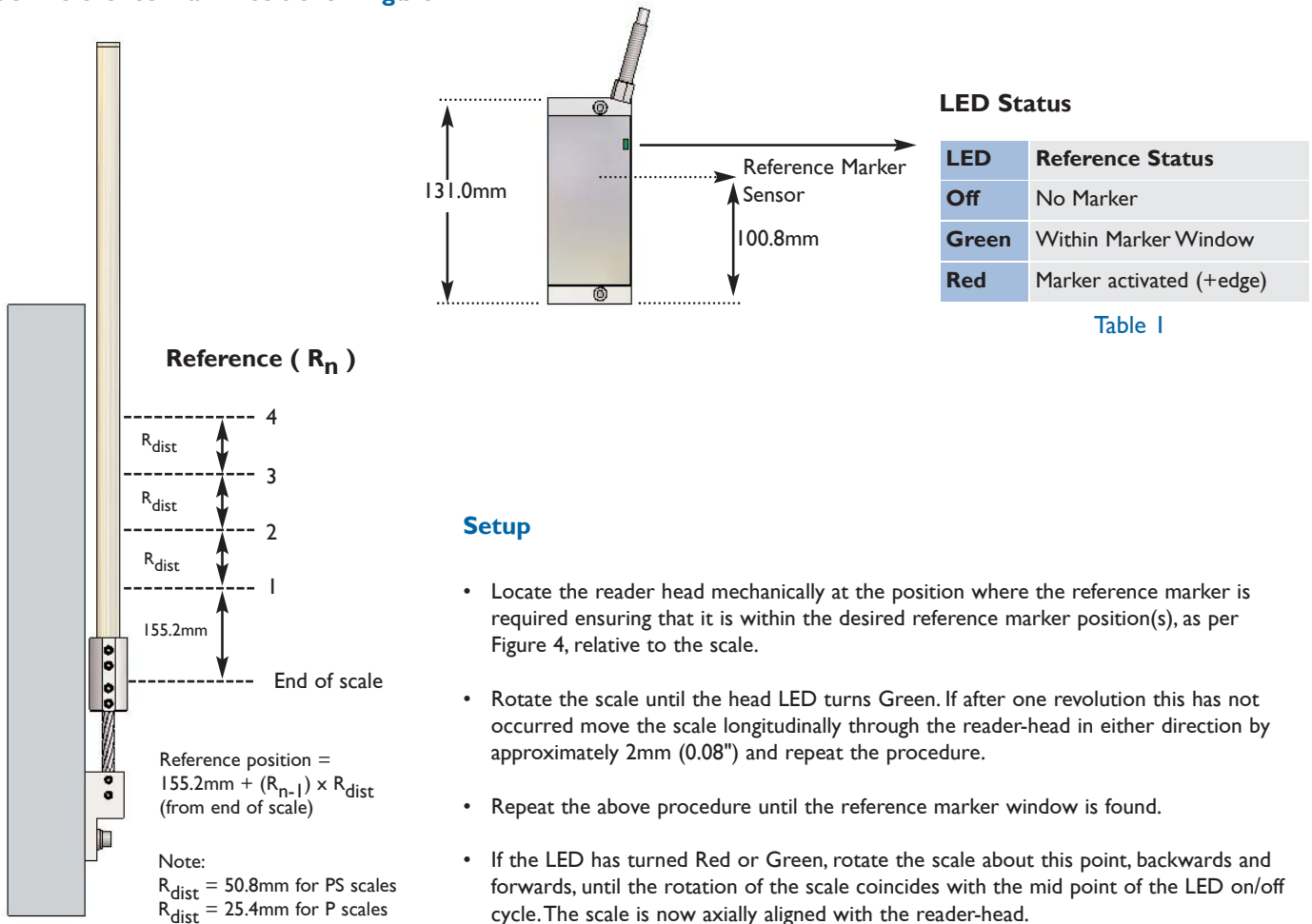

### Setup

- Locate the reader head mechanically at the position where the reference marker is required ensuring that it is within the desired reference marker position(s), as per Figure 4, relative to the scale.
- Rotate the scale until the head LED turns Green. If after one revolution this has not occurred move the scale longitudinally through the reader-head in either direction by approximately 2mm (0.08") and repeat the procedure.
- Repeat the above procedure until the reference marker window is found.
- If the LED has turned Red or Green, rotate the scale about this point, backwards and forwards, until the rotation of the scale coincides with the mid point of the LED on/off cycle. The scale is now axially aligned with the reader-head.
- If the LED is Green then the index position longitudinally is within approximately  $\pm 2\text{mm}$  of the current head position. In most circumstances this will be sufficient. If fine placement is required then the scale should be moved longitudinally until the LED turns Red. It is at this transition point that the index output will occur. (See Table I.) If the LED turns off and not to Red then move the scale in the opposite direction as you have moved away from the index position.
- The installation alignment is now complete and the scale should be firmly secured at the mounting points to prevent any future movement.